



CSU DOMINGUEZ HILLS



WELCOME



Health Wellness Recreation Center
02 / 20 / 2023
CHANCELLOR'S OFFICE DESIGN REVIEW



INTRODUCTION - PROJECT HISTORY

DEBORAH WALLACE / DR. WILLIAM FRANKLIN

PROJECT DESIGN

OZZIE TAPIA / WINSTON BAO

BUILDING SYSTEMS / SUSTAINABILITY

ERIK RING / BRYAN SEAMER / OZZIE TAPIA

REVIEWS

SUBHI MURAD / SABRINA LEMAN



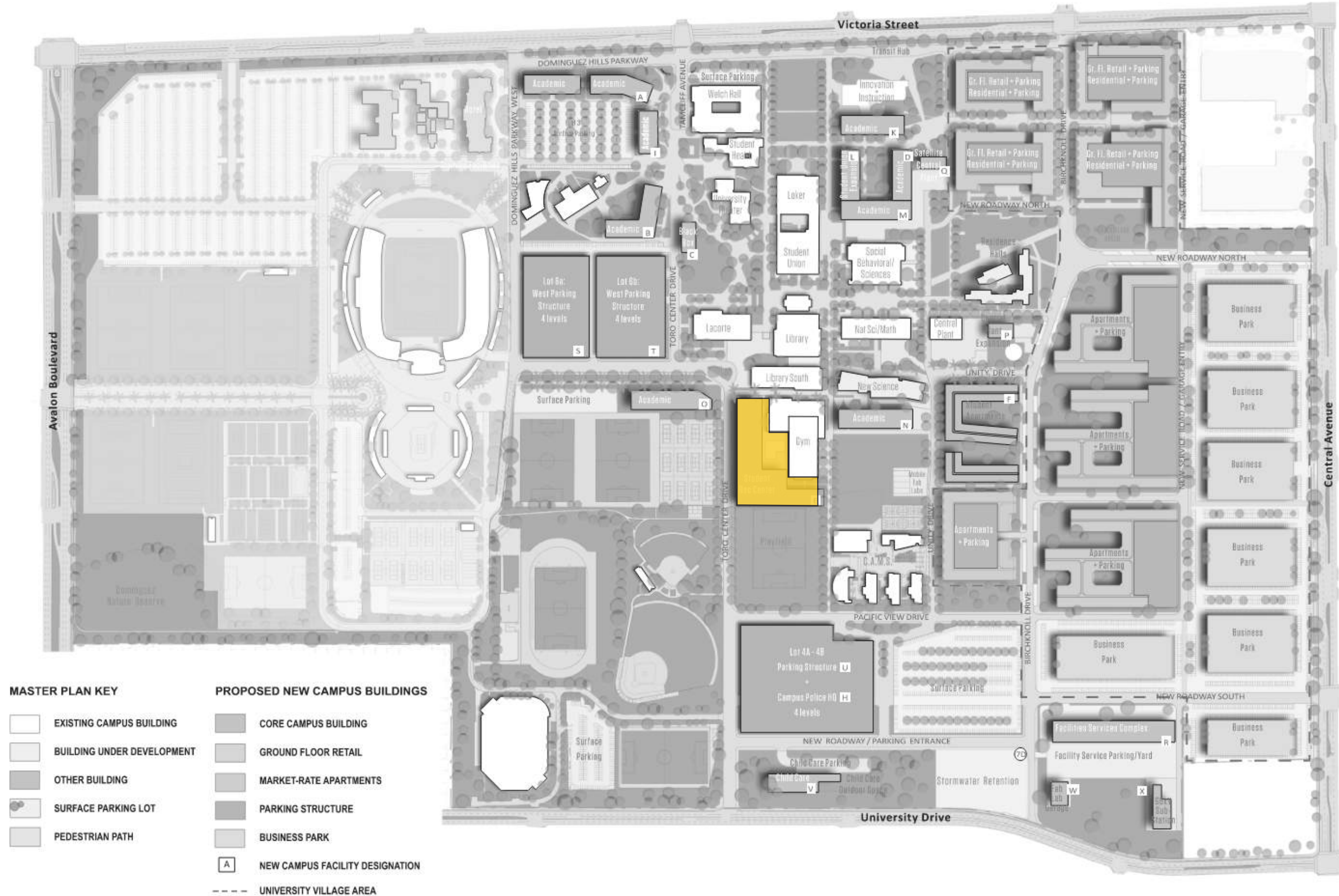

SCHEDULE / COST

SABRINA LEMAN / JACK GUZMAN / MARK VONDRAN







2018 CAMPUS MASTER PLAN / STRATEGIC GROWTH



MASTER PLAN KEY

-  EXISTING CAMPUS BUILDING
-  BUILDING UNDER DEVELOPMENT
-  OTHER BUILDING
-  SURFACE PARKING LOT
-  PEDESTRIAN PATH

PROPOSED NEW CAMPUS BUILDINGS

-  CORE CAMPUS BUILDING
-  GROUND FLOOR RETAIL
-  MARKET-RATE APARTMENTS
-  PARKING STRUCTURE
-  BUSINESS PARK
-  NEW CAMPUS FACILITY DESIGNATION
-  UNIVERSITY VILLAGE AREA

STUDENT VISION / 'GET CENTERED'

Student Centric - relevant, reflection of what students want and need, sense of empowerment and pride

Empowering - opportunities for growth and development, apply what students learn, make a positive impact

Multi-Dimensional - flexible, adaptable, multi-functional, multi-sensory, provides choice

Equitable - rooted in social justice, liberating, transformational

Collaborative - foster a sense of community, integrated into campus life and curriculum, #Torostogether

High Performance - sustainable, steward of natural resources, connected to place, nature and ecosystem, outdoors and views, iconic destination and centerpiece of campus

Inclusive - welcoming, judgement free, accessible to all, home away from home, sense of belonging, safe

Fosters Wellness - 8 dimensions of wellness



REDUCE NUMBER OF STORIES FROM 4 TO 3

CONNECT THE TWO BUILDING FOOTPRINTS

RELOCATE MECHANICAL SPACE TO TOP FLOOR

ELIMINATE BRIDGE

REDUCE NEED FOR WEST SHADING VEIL





CONSOLIDATE AND ENLARGE FITNESS SPACES

RECONSIDER NUMBER OF EXTERIOR TERRACES

INFORMED DESIGN | **CAMPUS VISION**





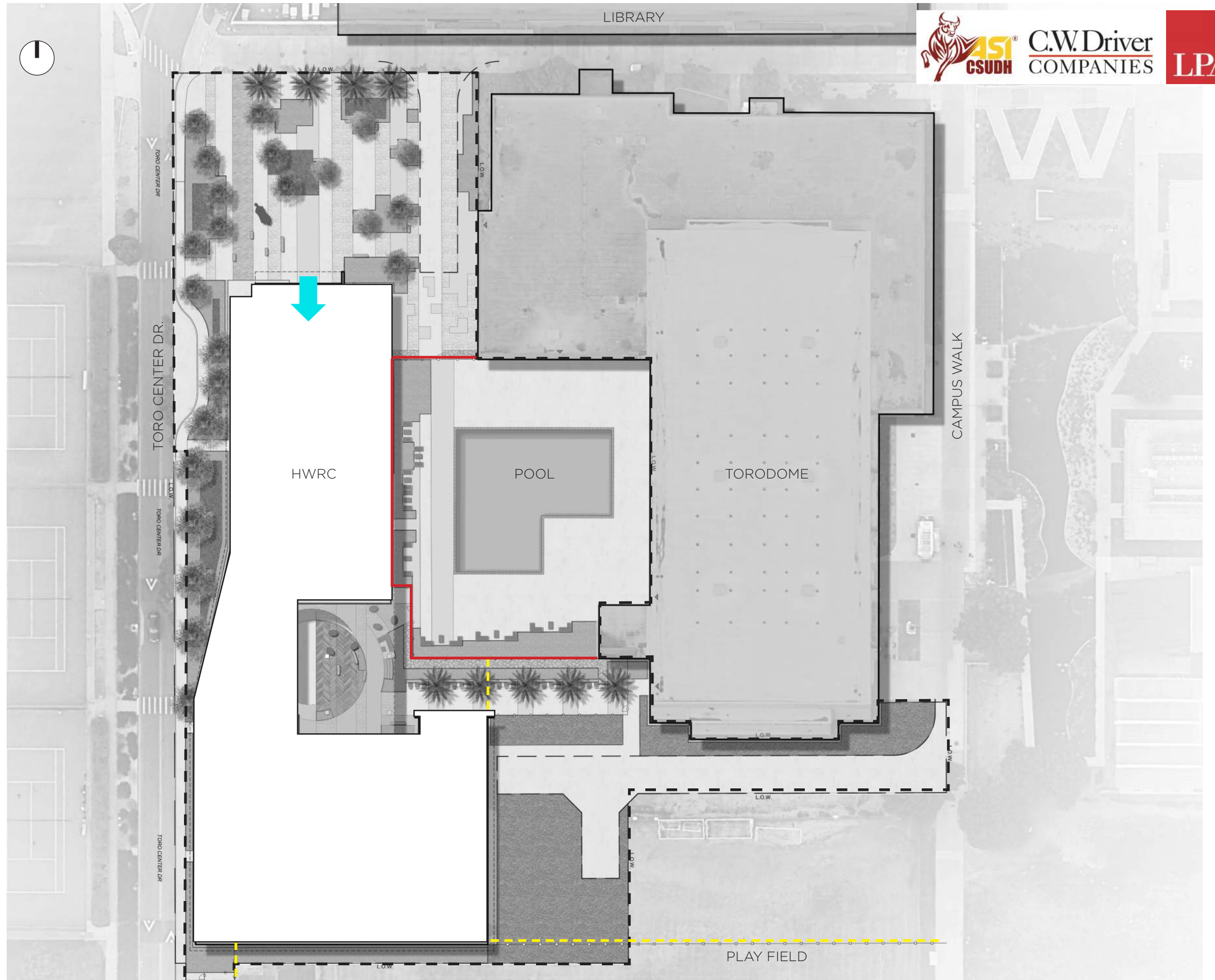

CSUDH HWRC / SITE PLAN

-  SINGLE POINT OF ENTRY
-  LIMIT OF WORK
-  FIRE LANE
-  PEDESTRIAN ACCESS
-  8' H SECURED FENCE





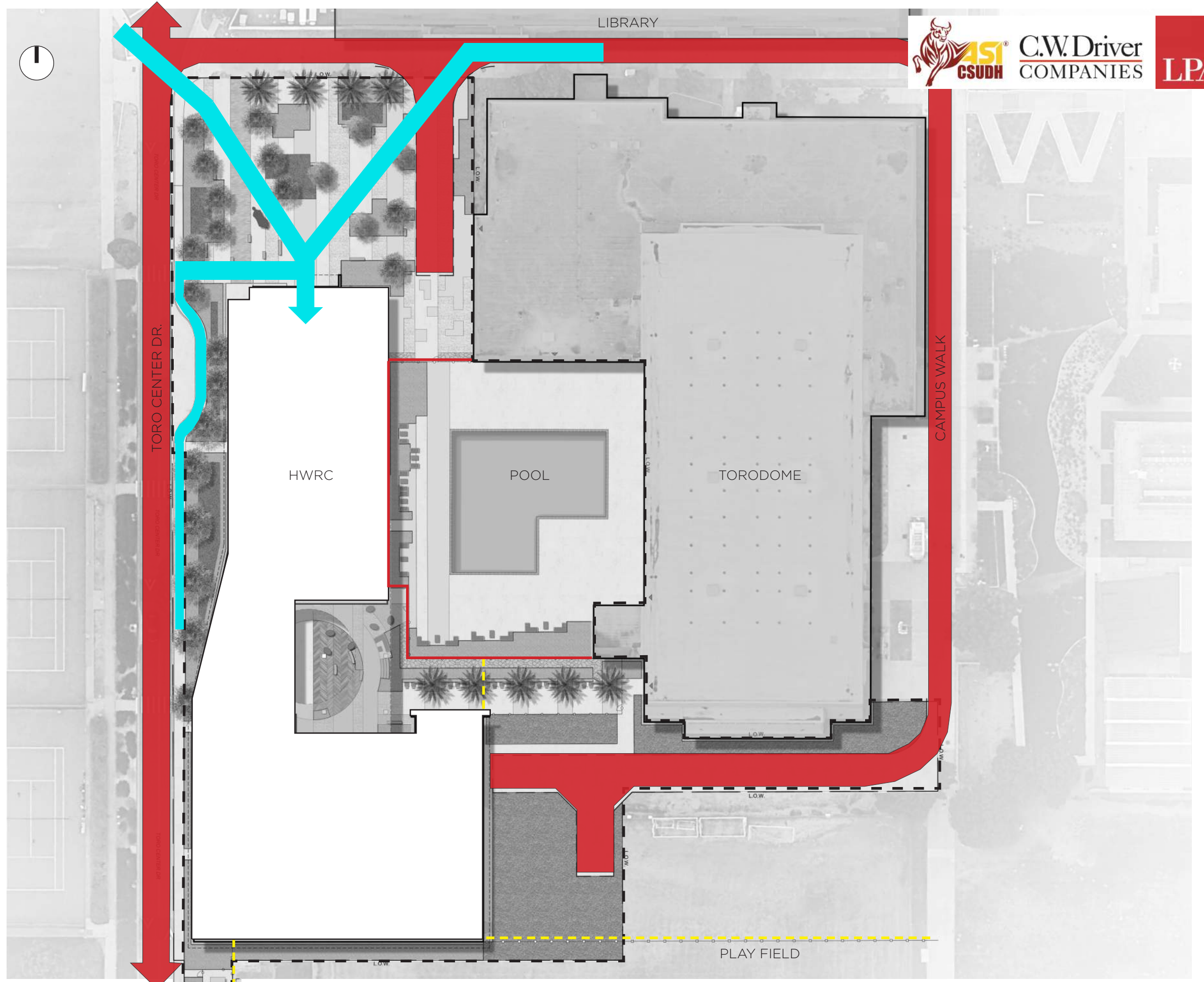

CSUDH HWRC / SITE PLAN

-  SINGLE POINT OF ENTRY
-  LIMIT OF WORK
-  FIRE LANE
-  PEDESTRIAN ACCESS
-  8' H SECURED FENCE



CSUDH HWRC / SITE PLAN

-  SINGLE POINT OF ENTRY
-  LIMIT OF WORK
-  FIRE LANE
-  PEDESTRIAN ACCESS
-  8' H SECURED FENCE

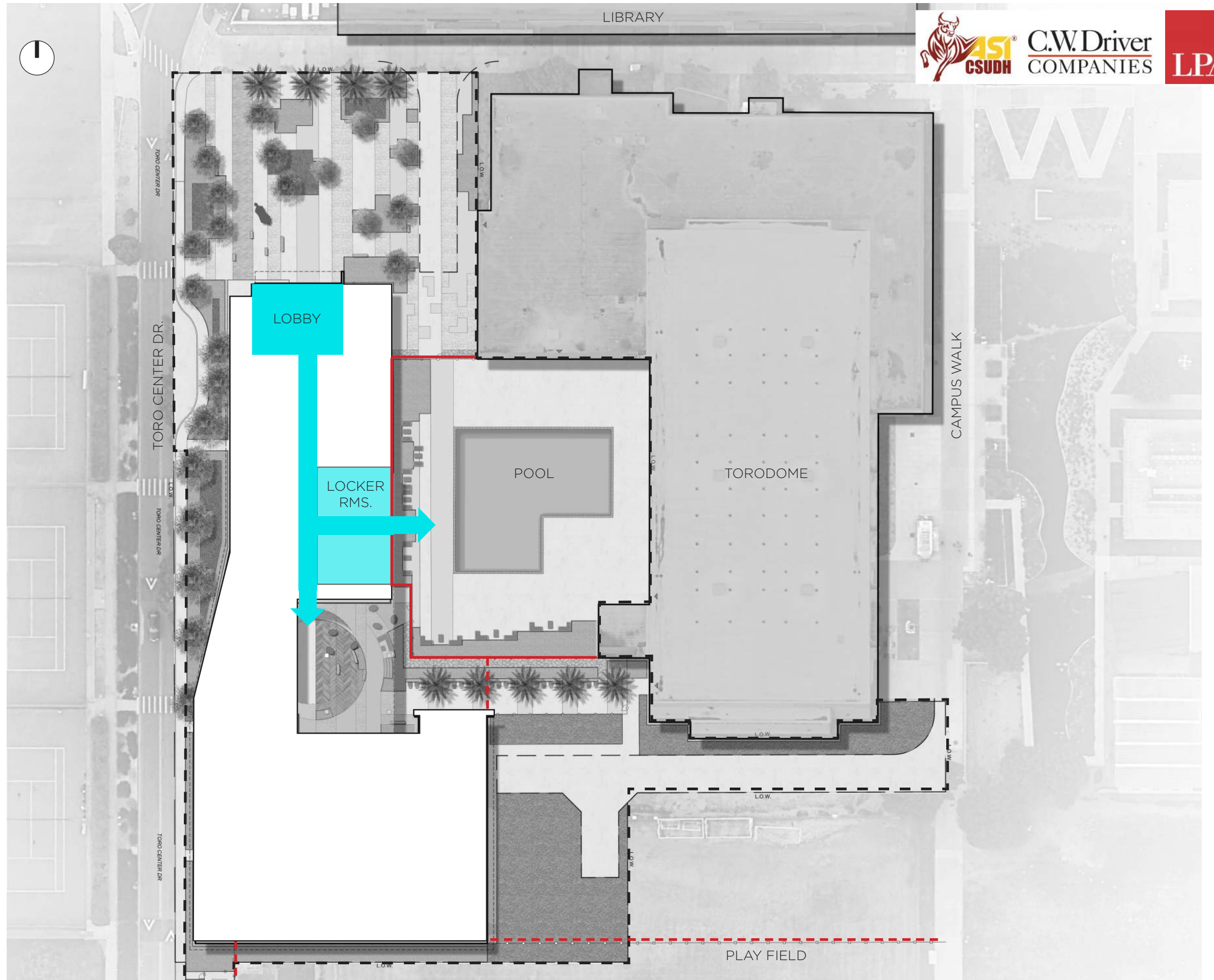

CSUDH HWRC / SITE PLAN

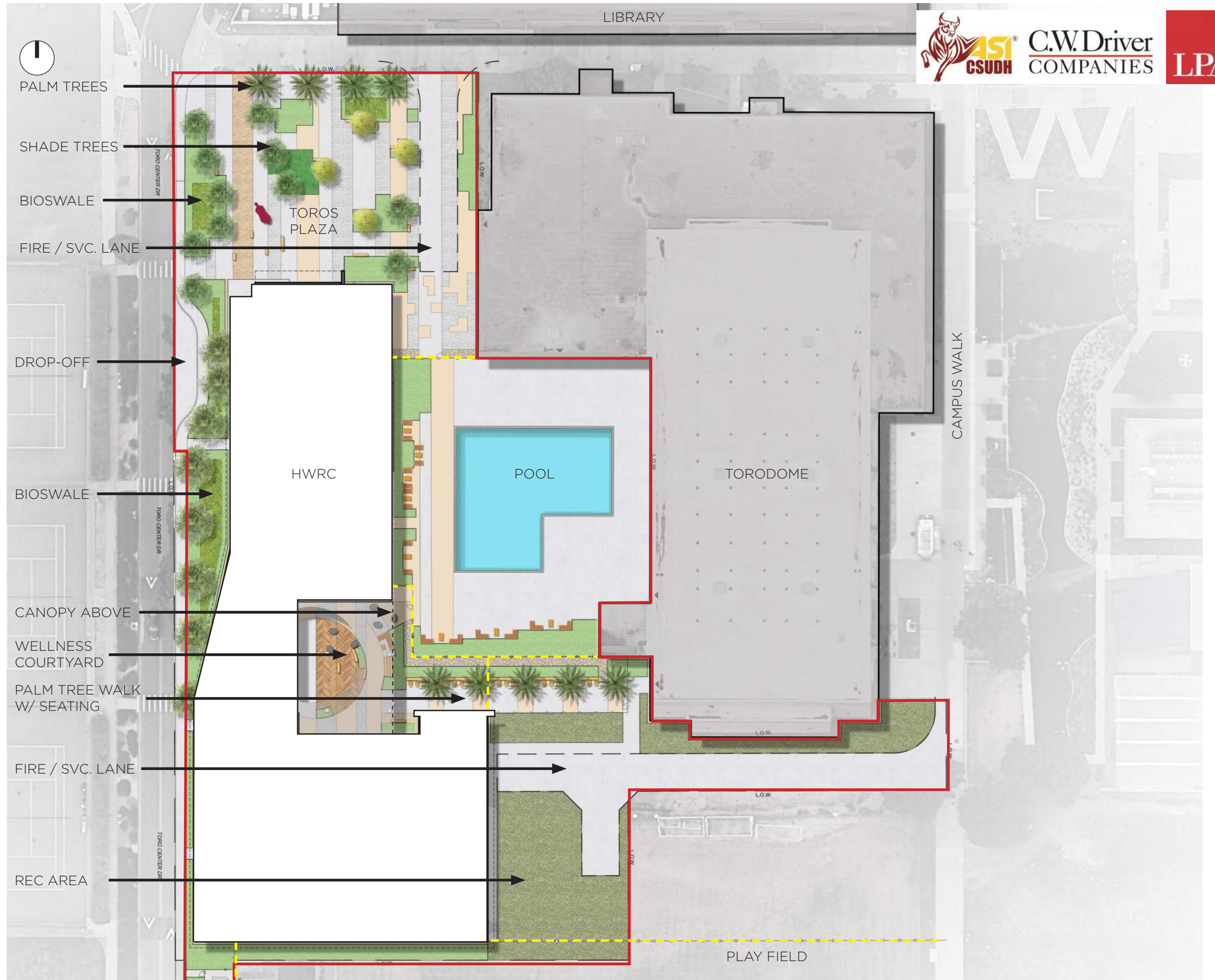

EXISTING TORODOME GYM
SOLID & INWARD FOCUSED

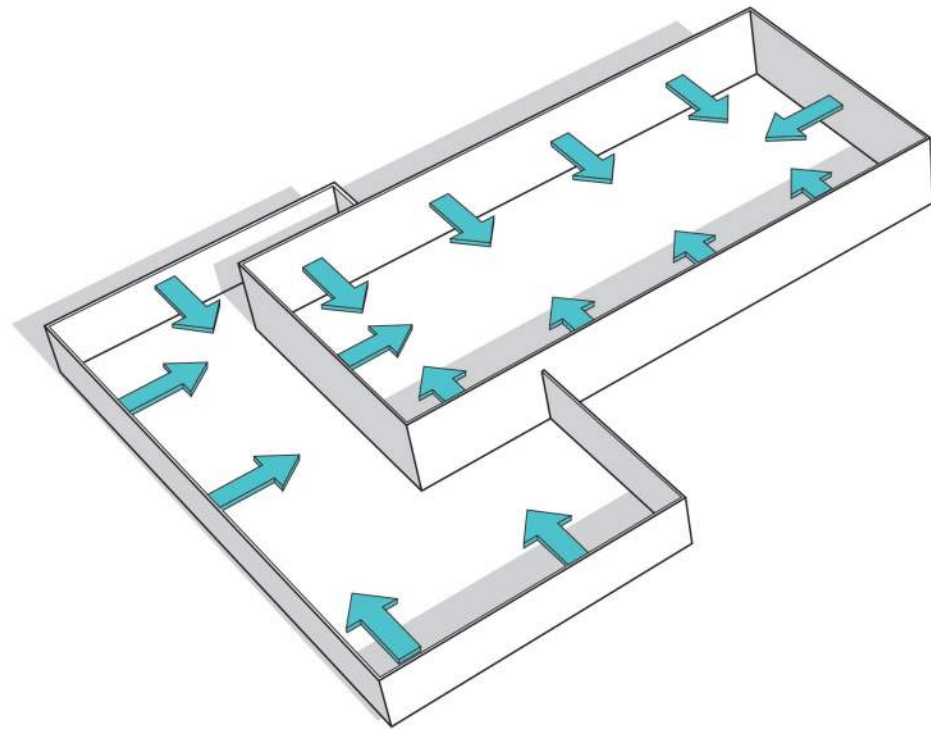

HEALTH WELLNESS & REC CENTER
TRANSPARENT & CONNECTED

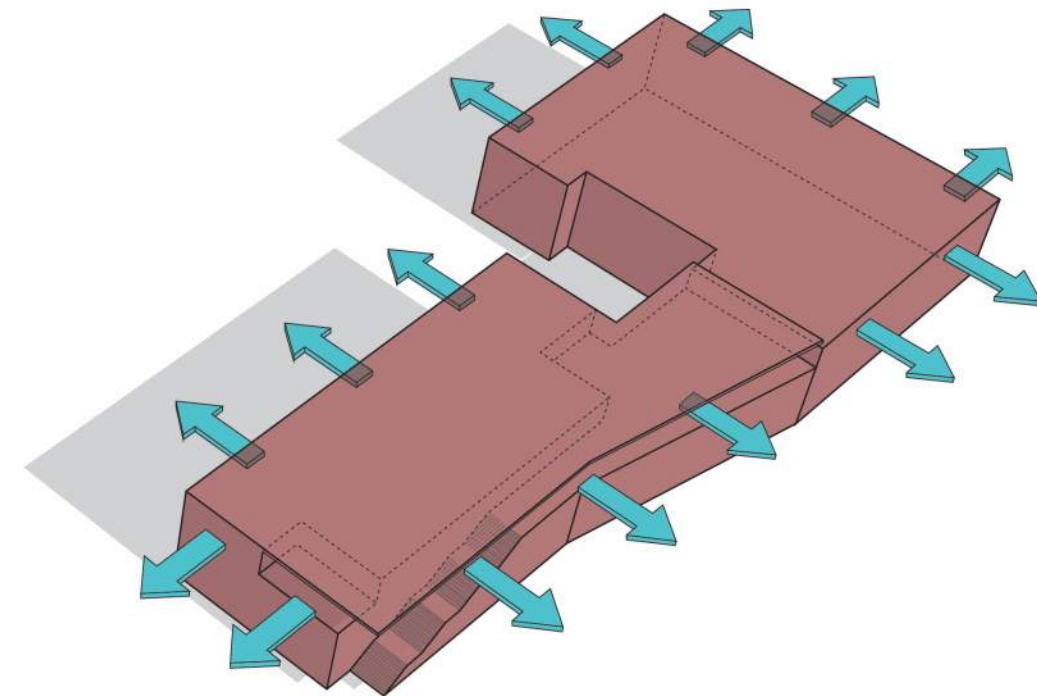

CSUDH HWRC / **CAMPUS-BUILDING**





CSUDH HWRC / TOROS PLAZA



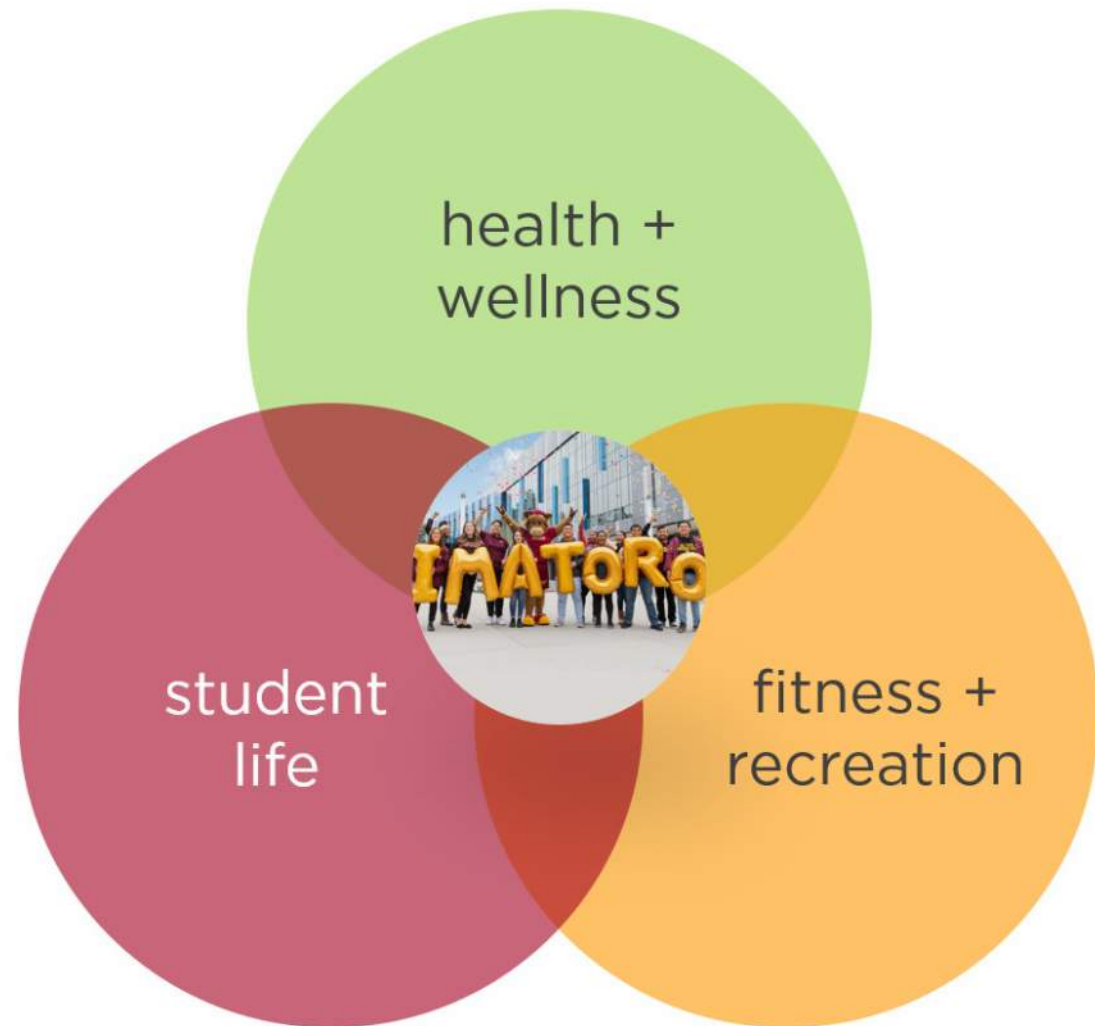

	Qty	ASF	Subtotal
FITNESS + RECREATION			
Lobby & Main Entry	1	2,000	2,000
Service Desk	1	200	200
Retail	1	50	50
Equipment Check-Out/Storage	1	400	400
Subtotal			2,650
Standard Court	1	6,300	6,300
MAC Court	1	8,400	8,400
Court Storage	2	300	600
Subtotal			15,300
Jogging Track	1	4,000	4,000
Subtotal			4,000
Fitness Center			
General Fitness	1	7,000	7,000
Strength Training	1	1,000	1,000
Fitness Neighborhoods	2	500	1,000
Subtotal			9,000
Multi-Purpose Rooms			
Studio A	1	2,500	2,500
Studio B	1	1,500	1,500
Equipment Storage	2	200	400
Subtotal			4,400
Assessment & Training Lab	1	1,000	1,000
Subtotal			1,000
Miscellaneous			
Gender Inclusive Showers/Lockers	1	400	400
Men's Showers/Lockers	1	800	800
Women's Showers/Lockers	1	800	800
Laundry Room/Supplies	1	300	300
General Building Storage	1	300	300
Subtotal			2,600

	Qty	ASF	Subtotal
HEALTH + WELLNESS			
Reception	1	300	300
Office	3	100	300
Open Relaxation Lounge	1	1,000	1,000
Mindfulness Room	1	500	500
Skills Lab & Activities Room	1	1,000	1,000
Multi-Purpose Room	2	300	600
Private Rooms	4	100	400
Health Exam Rooms	2	200	400
Lactation Room	1	150	150
Storage & Support	1	200	200
Subtotal			4,850

Support			
HWR-Administration & Staff			
Office	4	110	440
Open Workspace-Staff	8	50	400
Open Workspace-Shared	8	25	200
Work Area	1	300	300
Shared Breakroom	1	150	150
Athletics-Offices & Support			
Shared Touchdown Workstations	6	50	300
Athletic Ops	1	50	50
Work Area	1	50	50
Private Rooms	2	80	160
Coaches Showers/Lockers	2	300	600
Subtotal			2,650

Outdoor Spaces			
Lounge & Social			
Respite Garden			
Flex Deck			
Kitchen & Prep Area			
Nutrition Garden			
Fitness Circuit/Functional Fitness			

TOTAL BLDG.
 46,540 Total ASF
 72,999 **Total SUAM GSF**
 @63.5% efficiency
***includes covered exterior area,
 & interior mech. space**

CSUDH HWRC / GROUND FLOOR

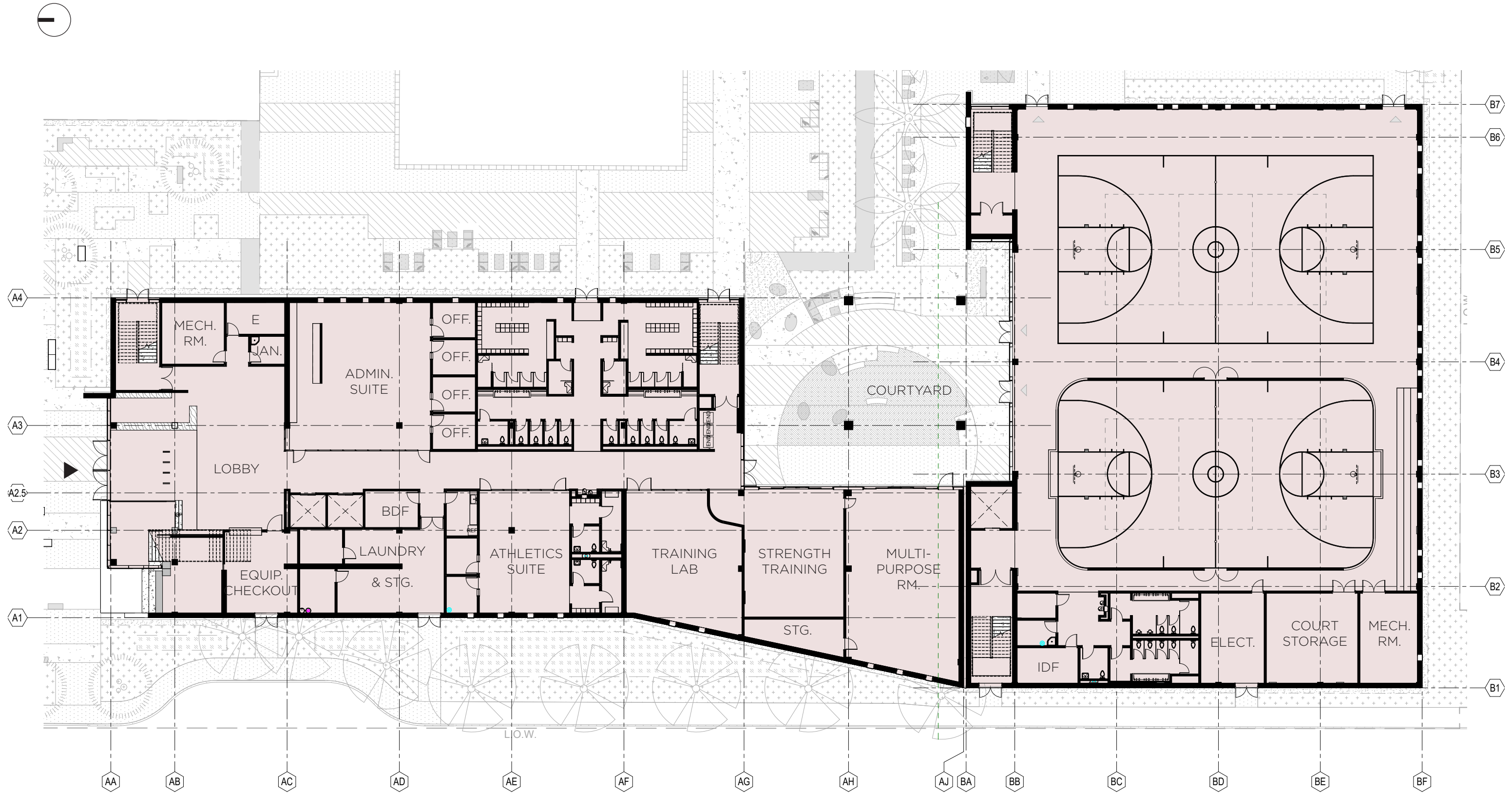



CSUDH HWRC / SECOND FLOOR

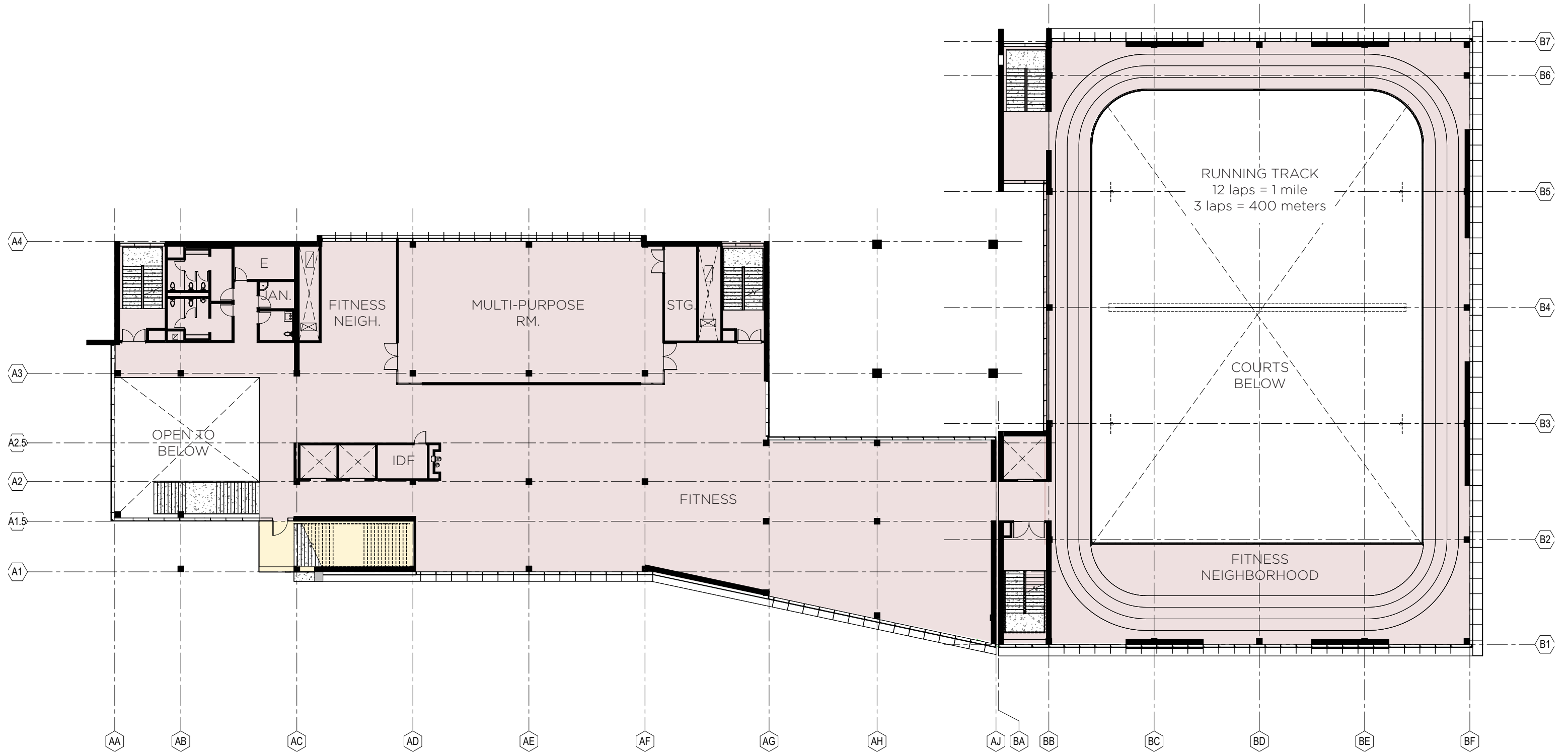



CSUDH HWRC / THIRD FLOOR

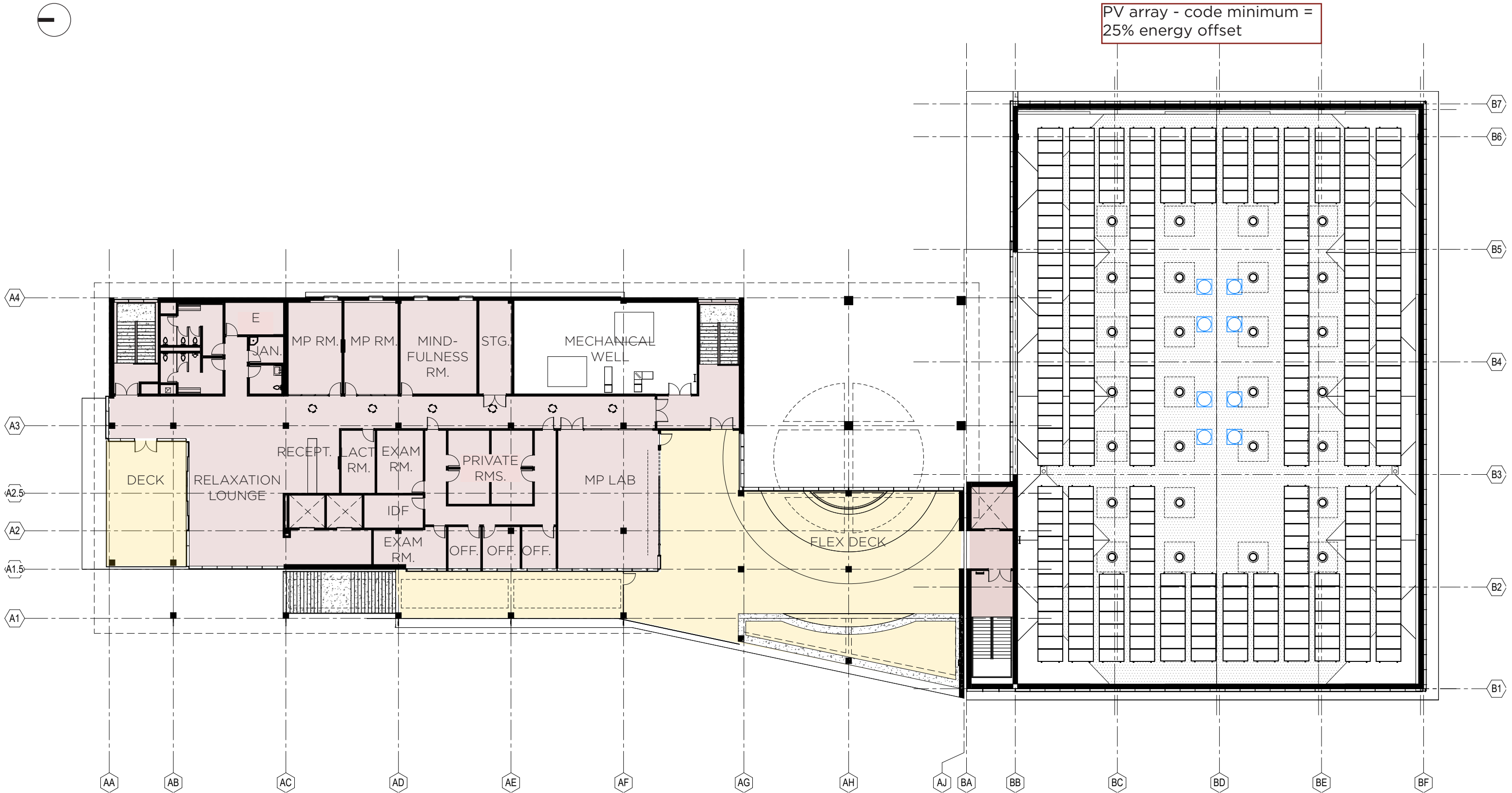





CSUDH HWRC / **NORTHWEST ALONG TORO CENTER DR.**



CSUDH HWRC / **ALONG TORO CENTER DR.**



CSUDH HWRC / **ALONG TORO CENTER DR.**





purposeful & timeless

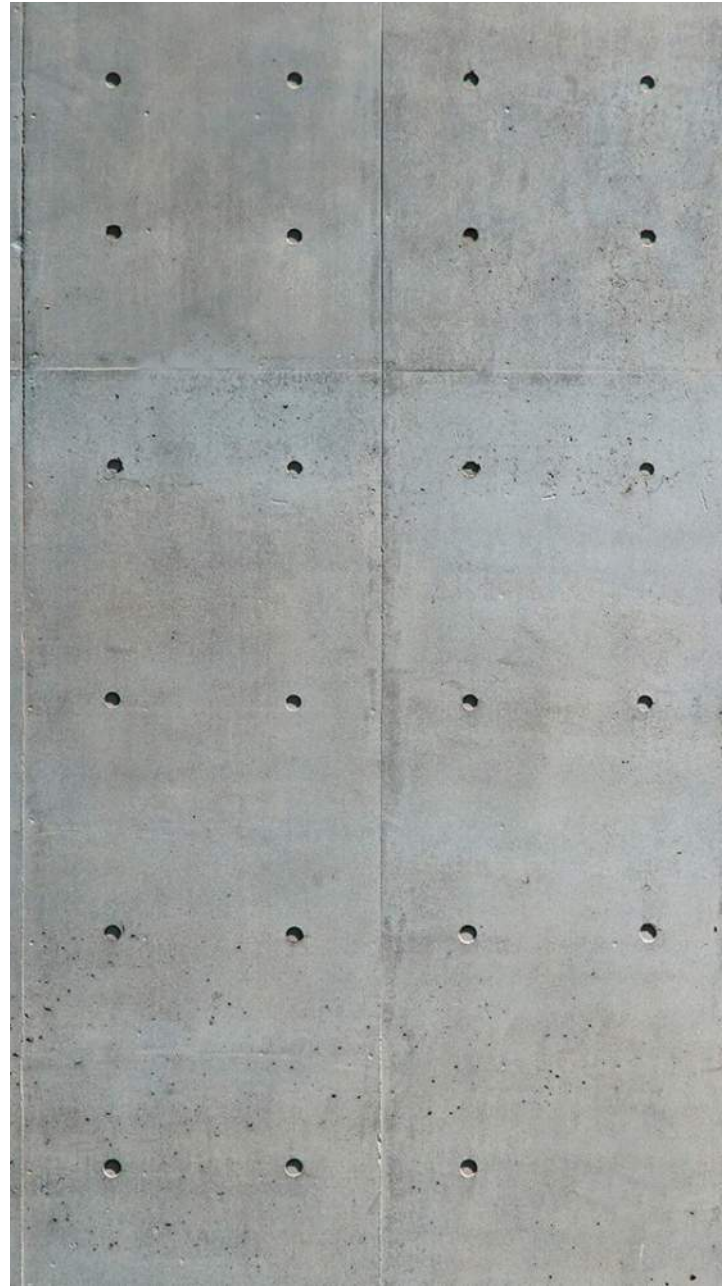

CSUDH HWRC / EXTERIOR ELEVATIONS



NORTH

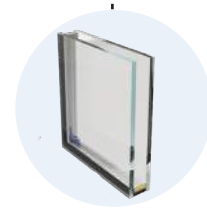

GLAZING
INSULATED GLAZING
UNIT - LOW 'E'



CONCRETE - SMOOTH

EXTERIOR SKIN
CONCRETE - FORMLINER

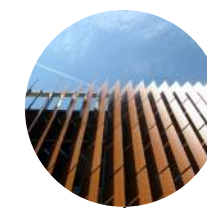

SOLAR SHADING
PERFORATED METAL
SUNSHADE



WEST

SOLAR SHADING
HORIZONTAL SUNSHADES

CSUDH HWRC / EXTERIOR ELEVATIONS

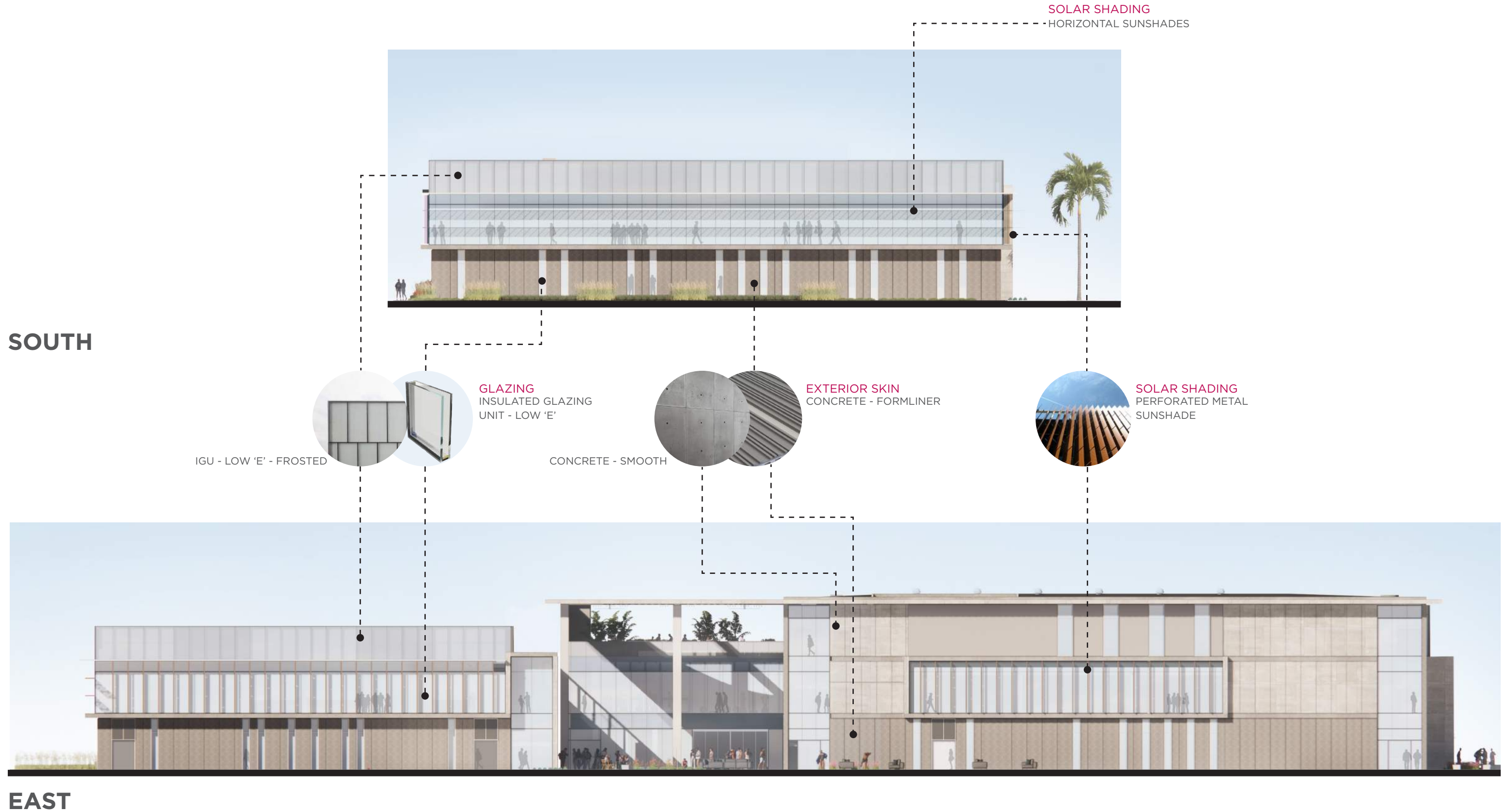

INFORMED DESIGN | **BUILDING SYSTEMS**

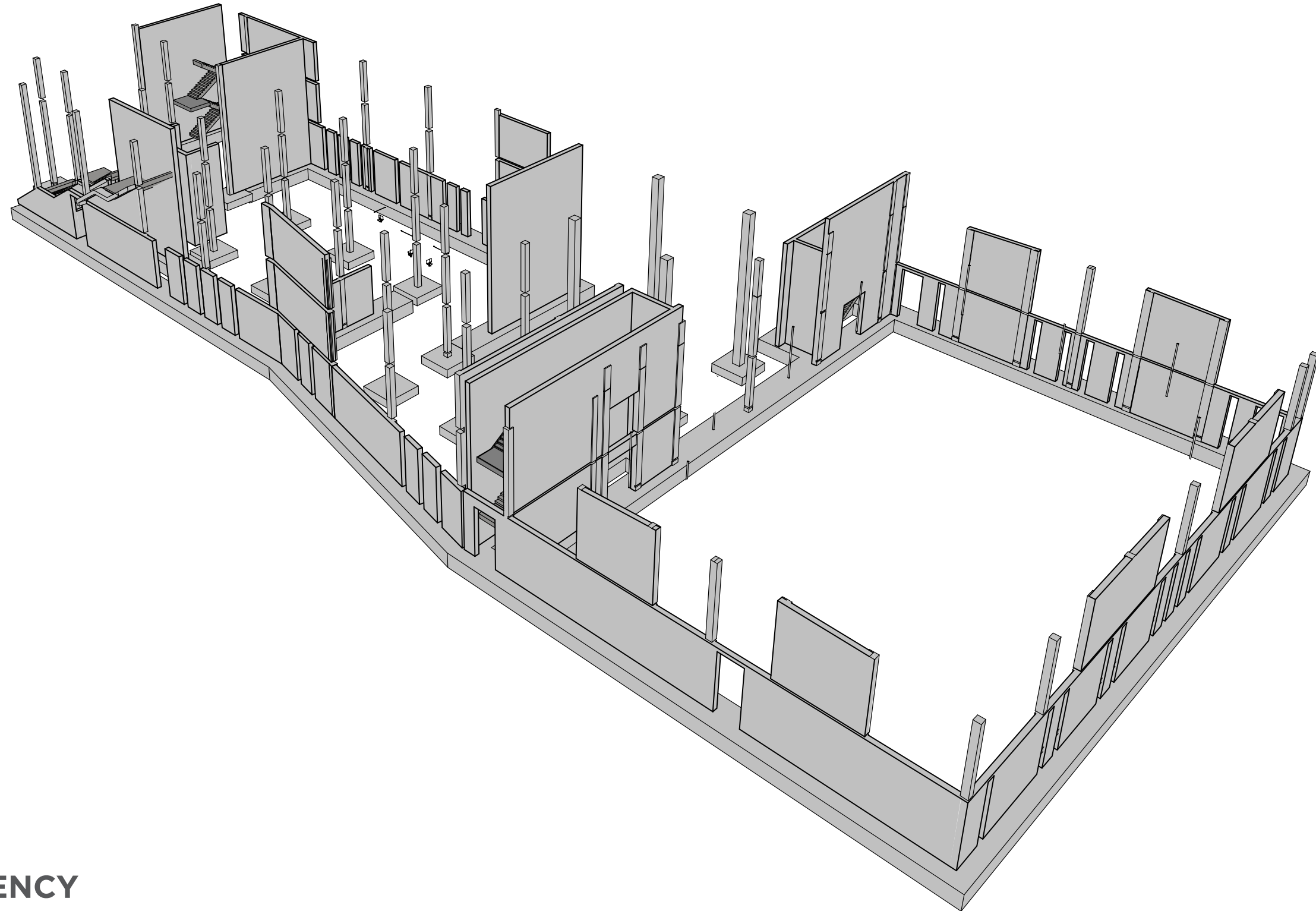

EFFICIENCY

SEISMIC RESILIENCY

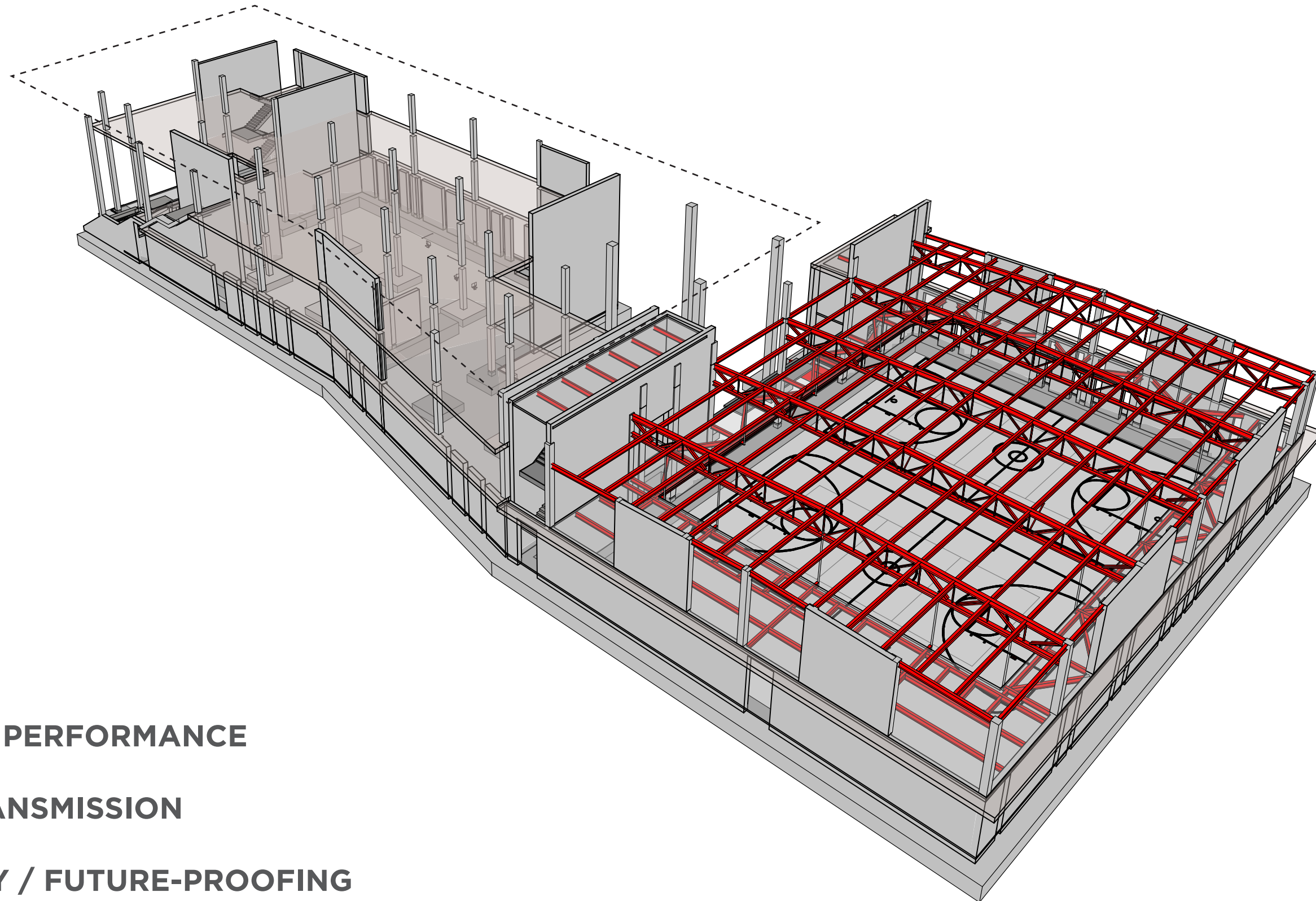

VIBRATION PERFORMANCE

SOUND TRANSMISSION

FLEXIBILITY / FUTURE-PROOFING

NO WASTED SPACE

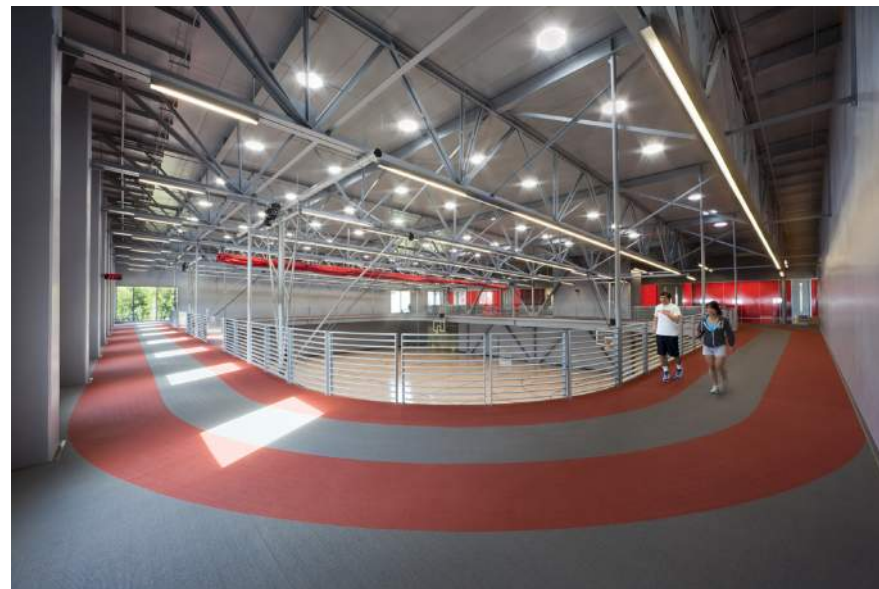
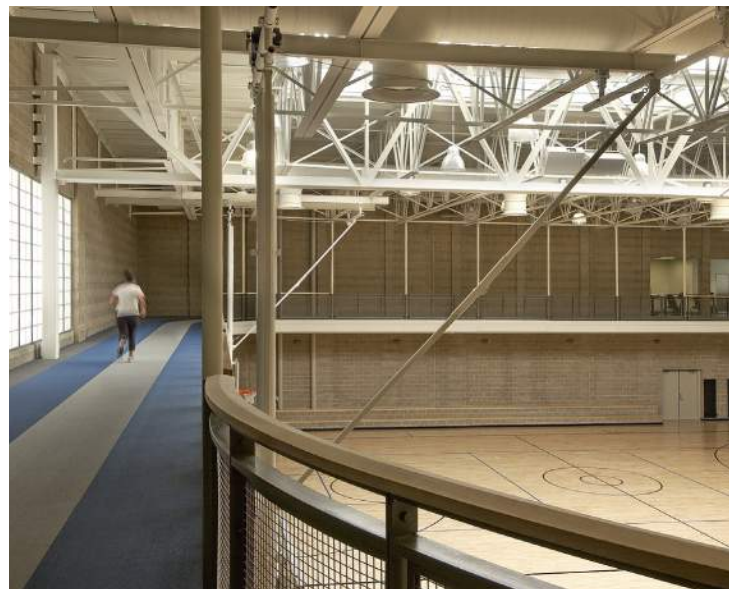
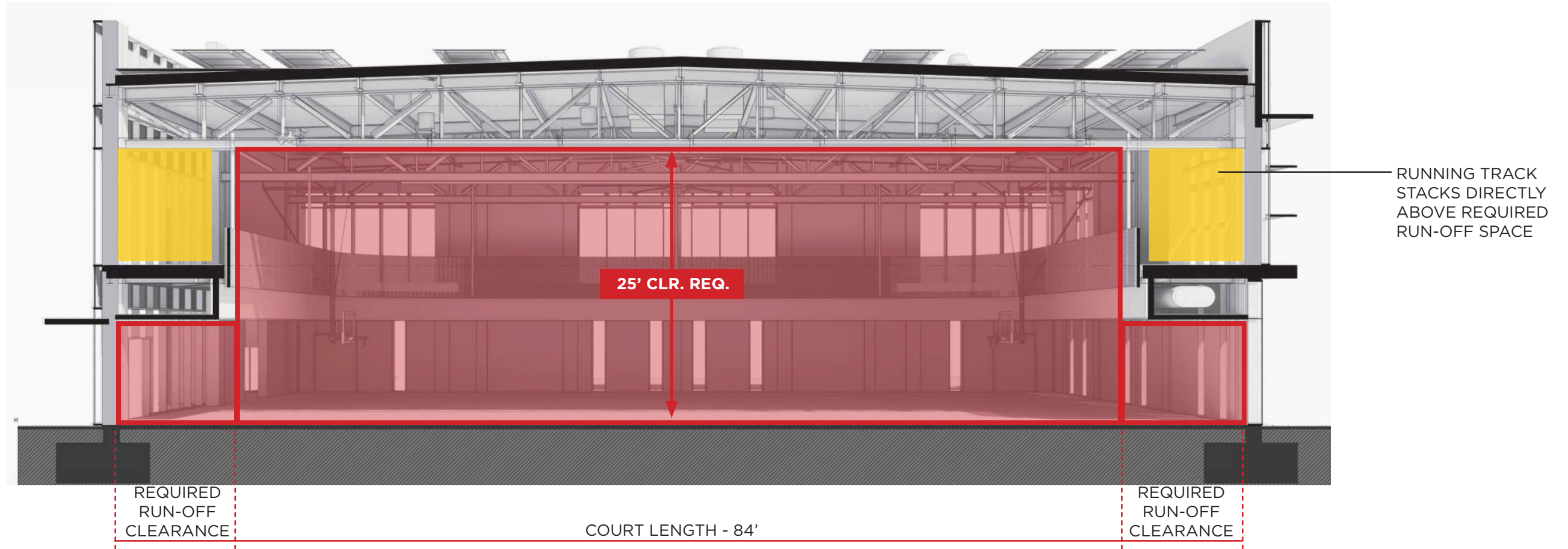

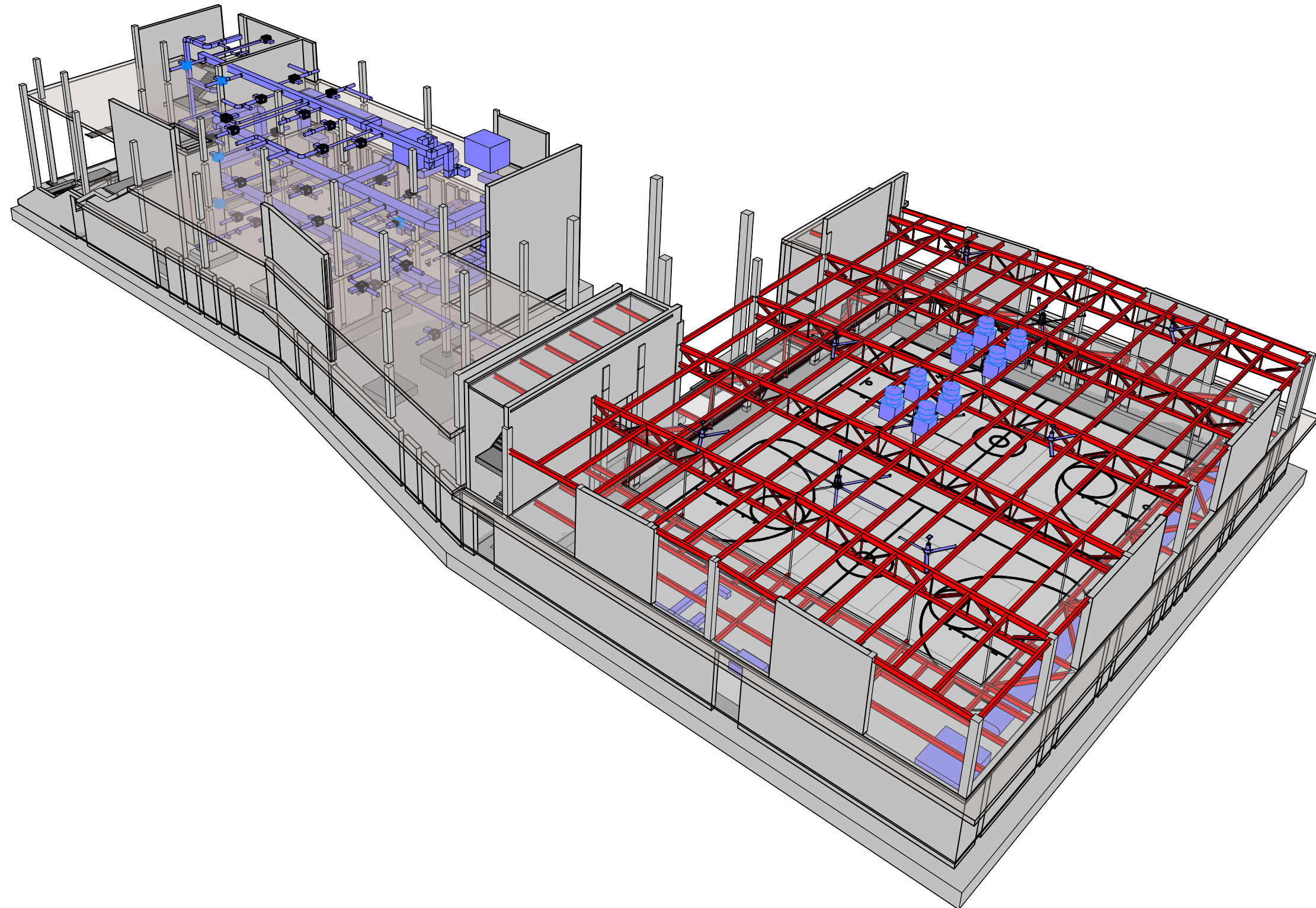

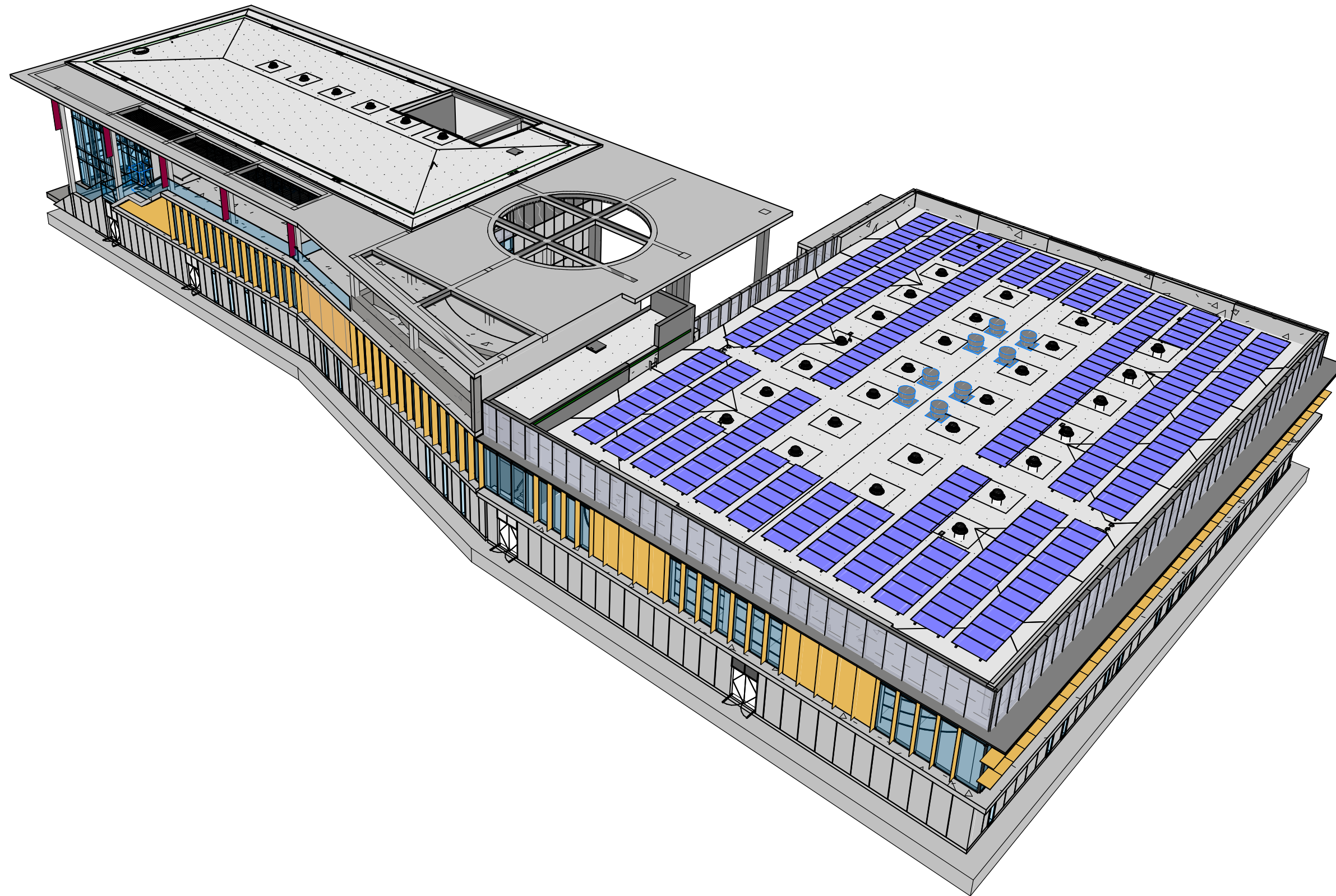

PREDICTED EUI: 33

LIGHTING POWER DENSITY TARGET: 0.50 [T24 PRESCRIPTIVE MAX AT 0.6]

CERTIFICATION TARGET: LEED GOLD

150 KW PHOTOVOLTAIC ARRAY ON GYM ROOF - APPROX. 25% OF BUILDING ENERGY

BATTERY ENERGY STORAGE SYSTEM - 250 KWH

ZERO SITE WATER RUN-OFF

DAYLIGHTING, INCLUDING TUBULAR SKYLIGHTS

MIXED MODE VENTILATION IN LOBBY & GYMNASIUM

CONNECTION TO ENERGY EFFICIENT CAMPUS CENTRAL PLANT



63% reduction over baseline
baseline EUI of 90 per AIA 2030 commitment



30615-M-Analytical

2:16:2023 - 08:53 AM

Back to Insight

Building Form

46.4
kBtu / ft² / yr

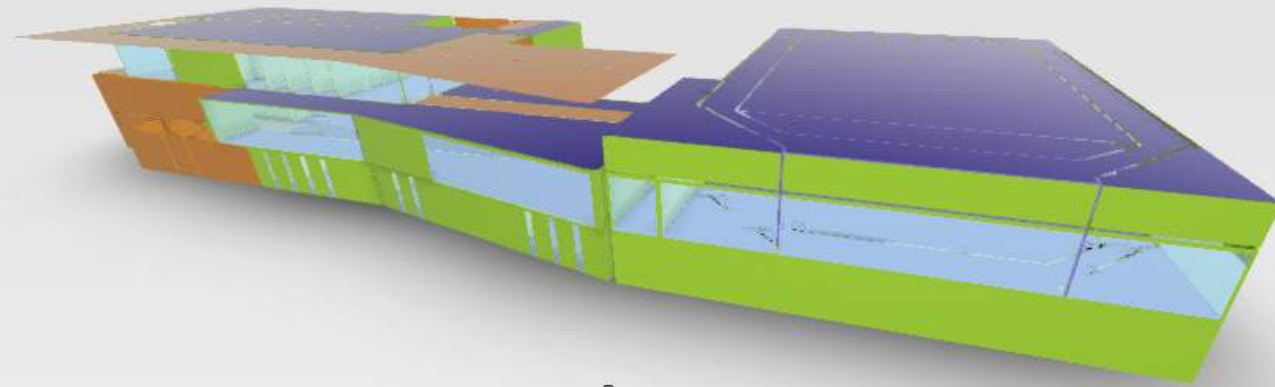

Window Shades - South

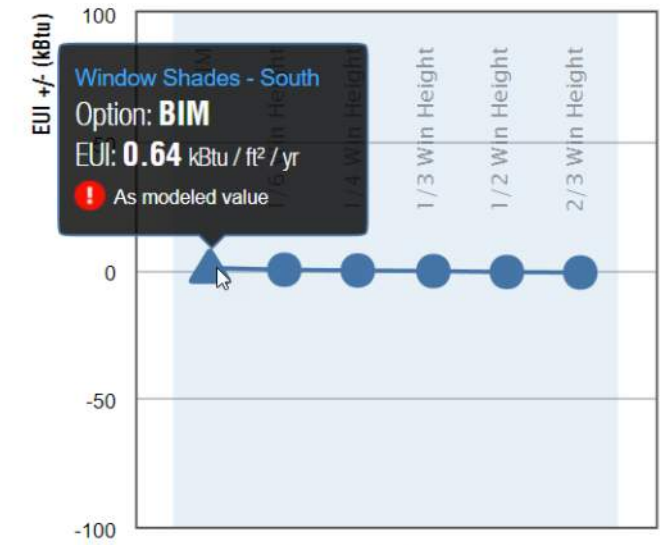

Benchmark Comparison
kBtu / ft² / yr

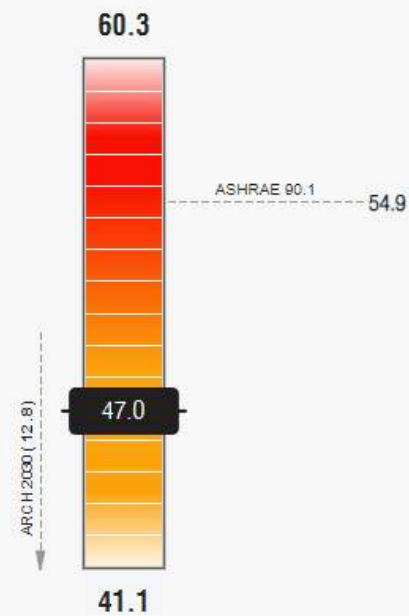

Model History
kBtu / ft² / yr

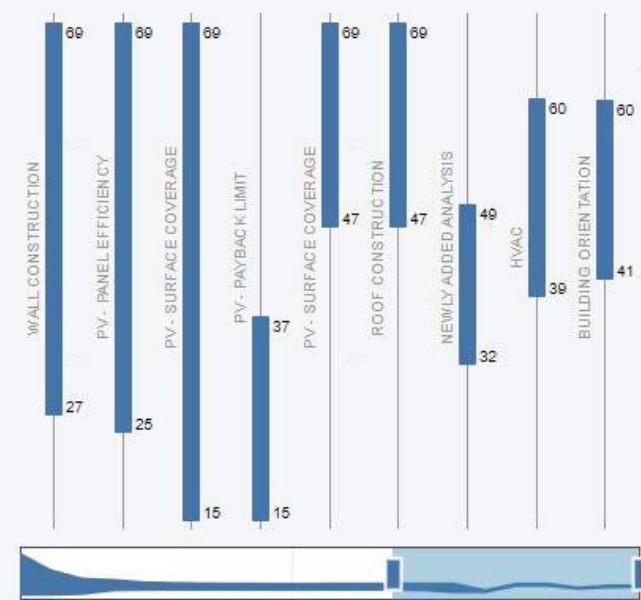

Plug Load Efficiency

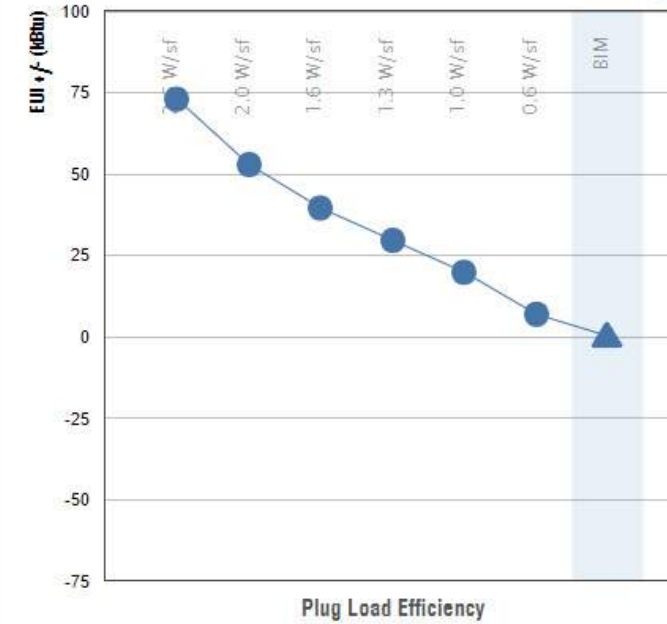

Lighting Efficiency

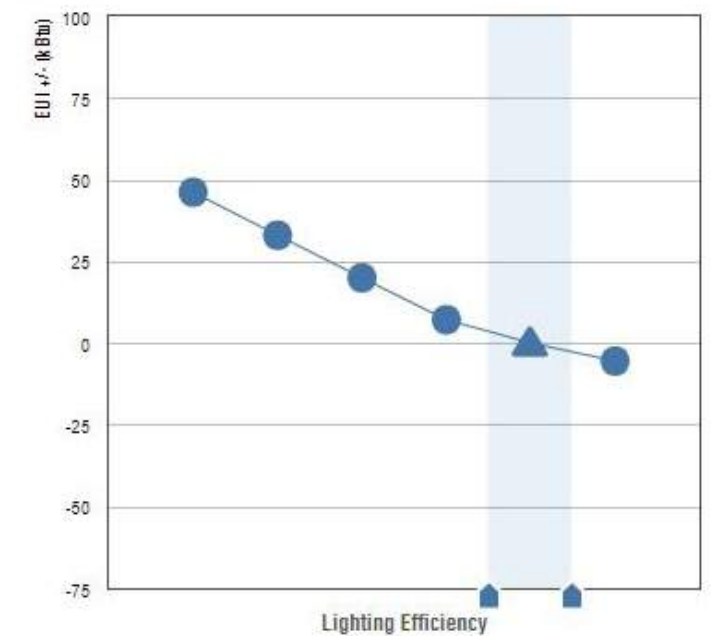

1 Energy efficiency

HVAC systems connect to air cooled water chilled central plant. PV array offsets 25% of building energy use.

2 Air

Gym & lobby utilize mixed mode ventilation with operable windows, leveraging prevailing breezes.

3 Daylighting + sun control

Daylighting strategies help reduce interior lighting demands.

4 Acoustics

Absorbent acoustical decking & perforated metal guardrail provide sound attenuation.

5 Thermal comfort

Ceiling fans promote air movement and allow higher thermostat setting, about 4 degrees without loss of comfort.

6 Views

External elevated views of campus and surrounding hills.

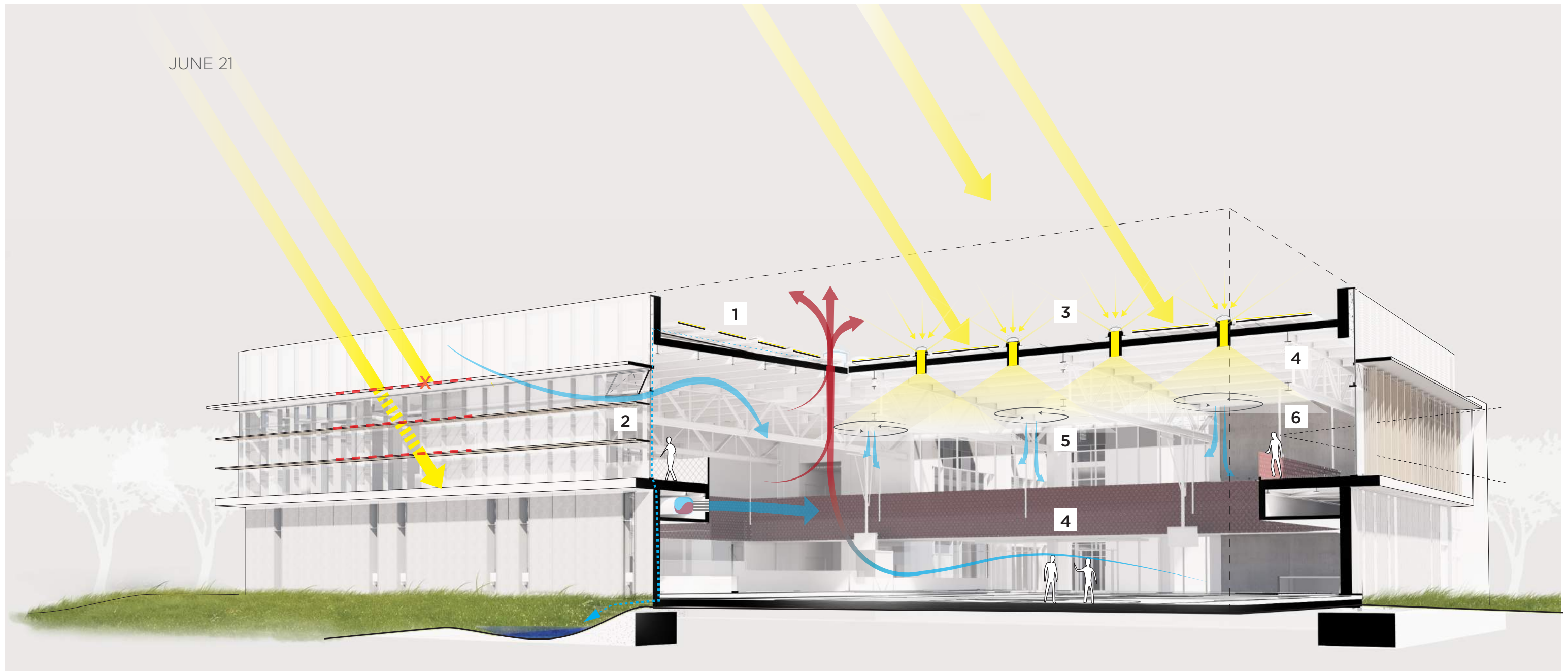

CSUDH HWRC / SUNSHADING & DAYLIGHTING ANALYSIS

WEST ELEVATION



JAN. 3 PM



MARCH 3 PM



JUNE 3 PM

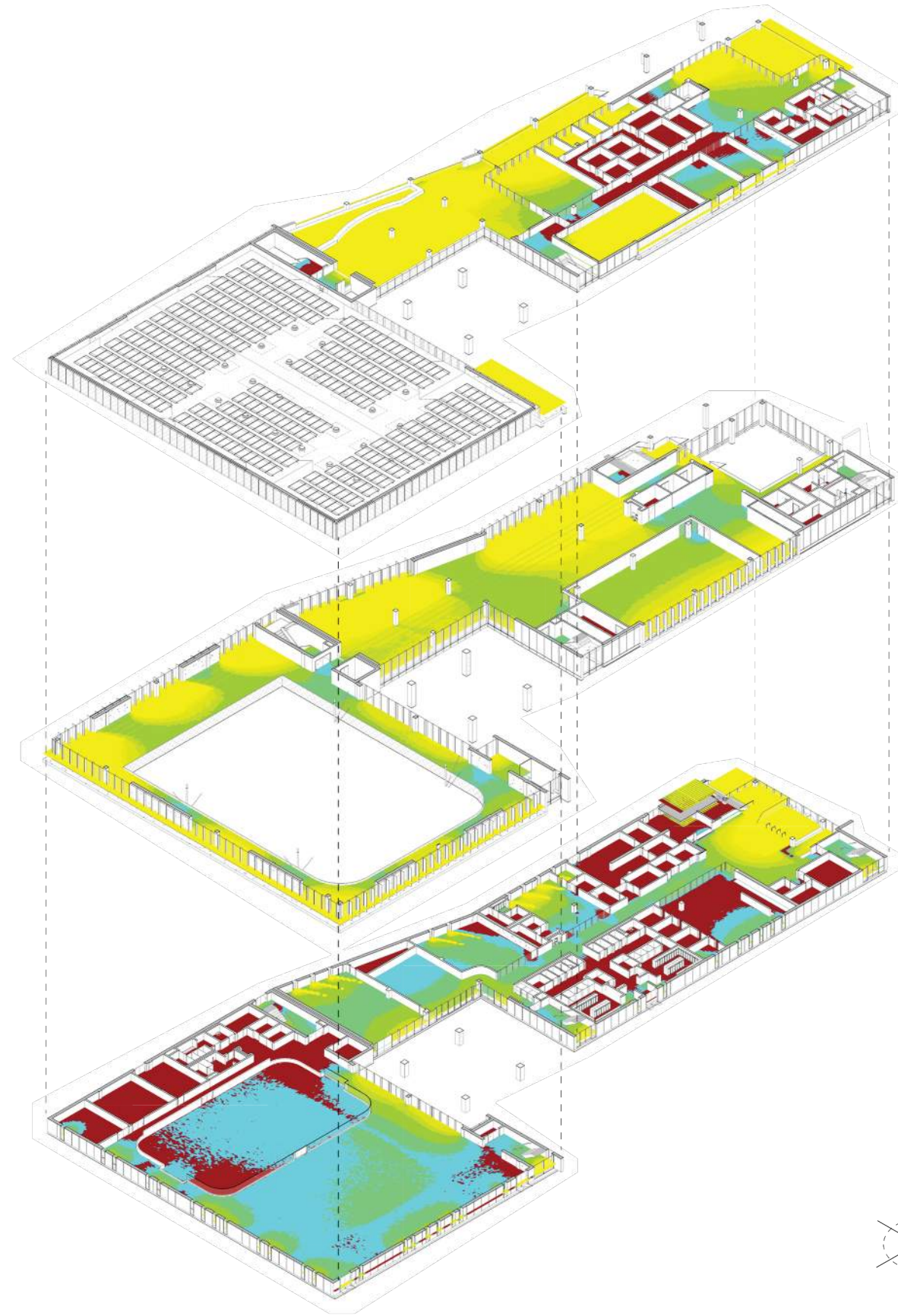



PEER REVIEWS

STRUCTURAL

MECHANICAL

ELECTRICAL

3RD PARTY CODE REVIEW

OFS

FLS



SCHEDULE & COST

Schematic Design	126 days	Wed 11/30/22	Wed 5/24/23	
Approved Revit Model Design to Engineers	1 day	Wed 11/30/22	Wed 11/30/22	
Schematic Design Package	5.2 wks	Wed 11/30/22	Wed 1/4/23	
<i>Peer Review (Mech, Elec, Seismic, OFS)</i>	16 days	Wed 1/4/23	Wed 1/25/23	
<i>Cost Estimating</i>	16 days	Wed 1/4/23	Wed 1/25/23	
Schematic Design Package to CPDC Planner	1 day	Tue 1/31/23	Tue 1/31/23	
75% Presentation to CSU Chancellor's Office	0 days	Mon 2/20/23	Mon 2/20/23	
<i>CSU CPDC Review Period</i>	12.2 wks	Tue 2/28/23	Tue 5/23/23	
CSU Chancellor Schematic Design Approval (BOT Meeting)	2 days	Tue 5/23/23	Wed 5/24/23	
Preliminary Plans	13 wks	Tue 2/28/23	Mon 5/29/23	
Peer Review	2 wks	Tue 5/30/23	Mon 6/12/23	54
Construction Documents	20 wks	Tue 5/30/23	Mon 10/16/23	54
Peer Review and Agency Approvals	27 wks	Tue 10/17/23	Mon 4/22/24	56
Bidding and Contracts	17.6 wks	Thu 11/16/23	Mon 3/18/24	
Construction	90 wks	Tue 3/19/24	Mon 12/8/25	58
Commissioning and University Move-In	6 wks	Tue 12/9/25	Mon 1/19/26	59
Occupancy	0 days	Mon 1/19/26	Mon 1/19/26	60
Project Closeout	7 wks	Tue 1/20/26	Mon 3/9/26	61



COST ESTIMATE

CPDC 2-7

**TOTAL:
68,905,632**

**TOTAL GMP:
68,907,000**

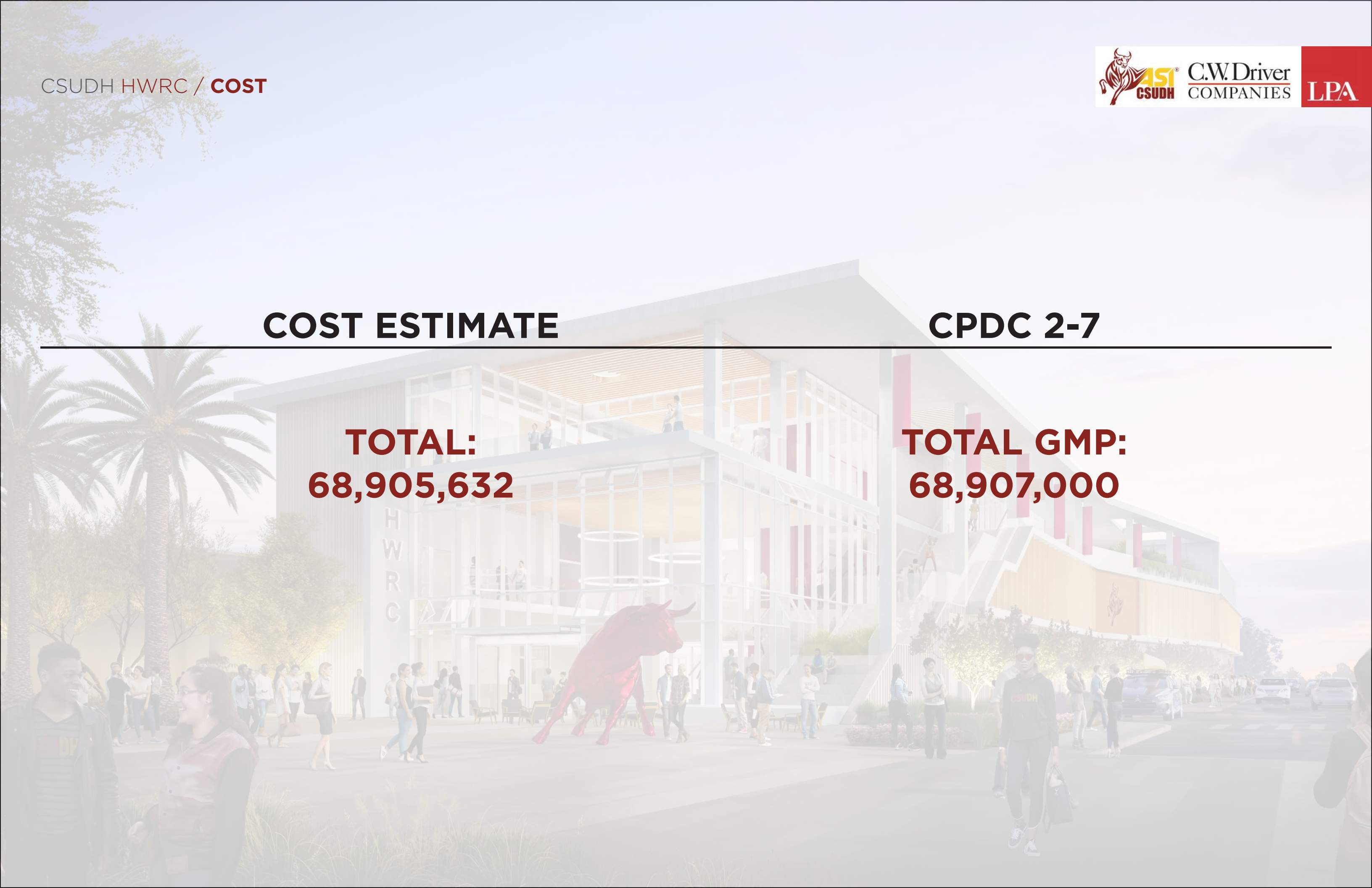



QUESTIONS & ANSWERS

CSU DOMINGUEZ HILLS



I Make
Champions
I'M A TORO

DANIEL GUERRERO
Director of Athletics
UCLA

CLASS OF 1993

I Make
Champions
I'M A TORO

JEROME HORTON
Board Member
California State Board
of Chiropractors

I Make
Champions
I'M A TORO

I Make
Champions
I'M A TORO

THANK YOU!

